

Description

The PTSC-M series is a combined pressure temperature sensor used for industrial applications. The PTSC-M series is available with various pressure ranges, absolute and gauge pressure options, supply voltages, output signals, electrical and mechanical interfaces to make it easy to adopt and to reduce the workload on the engineer. For enhanced version see PTSC-EP Series sensor.

The PTSC-M series has been designed, tested and proven to withstand the harshest requirements of the industry. The PTSC-M includes EMI/RFI protection and is operational under extreme vibration and mechanical shock, and temperatures as low as -40 °C and up to +125 °C.

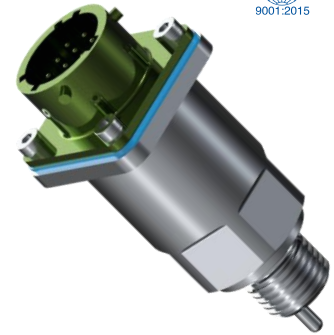

PTSC-M Series Specifications

Performance

Pressure	
Accuracy	≤ ±0.5% at RT
Non linearity	≤ 0.15% FS
Lifetime Drift (1000h, +125 °C)	≤ 0.5% FS
TEB (-40 °C to +125 °C)	≤ 2.5% FS
TEB (0 °C to +85 °C)	≤ 1.0% FS
Proof pressure	2 x FS pressure
Burst pressure	3 x FS pressure
Pressure response	< 1ms

Temperature	
RTD operating temp. range	-200 +600 °C
RTD compensated temp. range	-50 +600 °C
Accuracy	PT100 / PT1000 Class B
Temp response time	< 20s
RTD max current	PT100 : 1.4mA
	PT1000 : 0.4mA

Environmental Specifications

Temperature (Operating)	-40 +125 °C
Temperature (Storage)	-40 +125 °C
Shock	40G 11ms Half Sine 3-axis per MIL-STD-810G, Method 516.6
Vibration	Random Vibration: 15 to 2000 Hz @ approx. 50G (peak) per MIL-STD-810G, Method 514.6
Salt Fog	MIL-STD-810G CHG-1, Method 509.6
Sealing	IP67 per IEC-60529

Electrical Specifications

Supply voltage ¹⁾	0.5-4.5V Output, 9-32VDC 2-10V Output, 12-32VDC
Output temperature ¹⁾	PT100 / PT1000
Current consumption	< 10mA
Reverse voltage protection	Yes
Electrical interface	PT02A12-8P
Bonding	see details ²⁾

Mechanical Specifications

Material ³⁾	304 Stainless Steel
Sealing	PTFE
Pressure port	See ordering information
Weight	75g (Dependent on configuration)
Mounting Torque	7.5Nm

1) Please contact us for custom solutions.
 2) Enclosure and cable offers full and continuous protection EMI/RFI effects.
 3) Production in 316L Stainless Steel is available.

Ordering Information

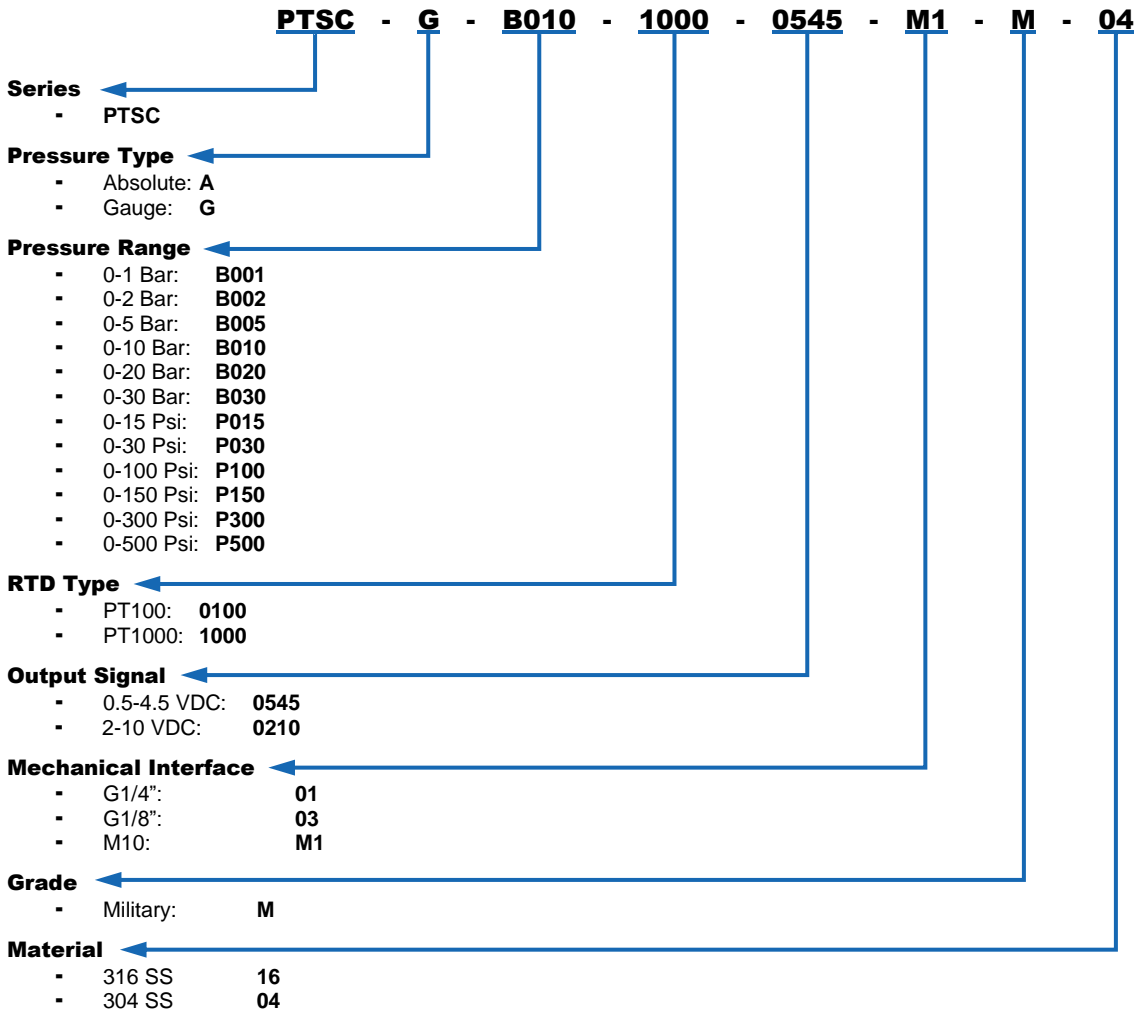

Typical ordering example: Gauge, 10 bar pressure, PT1000 RTD, 0.5-4.5 output signal, M10 mechanical interface, Military grade, SS 304 material: **PTSC-G-B010-1000-0545-M1-M-04**

For stock and price inquiry please contact us at: sales@taelco.com or www.taelco.com/en/contact-us/
 Shipping, customs fees etc. are not included in the price quotation. TAE LCO is not responsible for customs clearance.

Dimensions and Interfaces

Housing & Pressure Interface

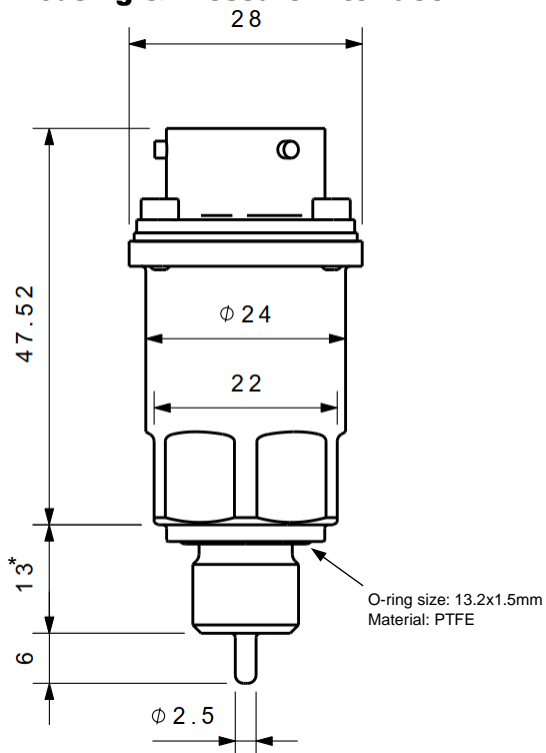

Electrical Interface (I/F)

The electrical I/F is a PT02A12-8P compatible circular connector.

Connector Pin Out	
Supply +	A
Pressure Signal	B
GND	C
Temp Signal 1	D
Temp Signal 2	E
No Connect (NC)	F
No Connect (NC)	G
No Connect (NC)	H

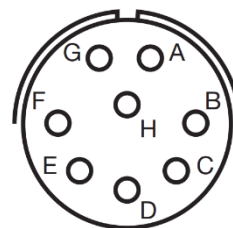

*) For G1/4" thread interface. Please contact us about details for different thread interfaces.

Revision History

Revision	Reasons for Revision	Issue Date
REV A	<ul style="list-style-type: none">• First revision.	24.12.2024

Notice and Disclaimer

The information presented here is believed to be correct. TAE LCO assumes no responsibility for the use of its products, nor for the use of any information that has been provided. The user is responsible for determining the suitability of the product for the user's application or use. Specifications subject to change without notice. Trademarks are the property of their respective owners.